

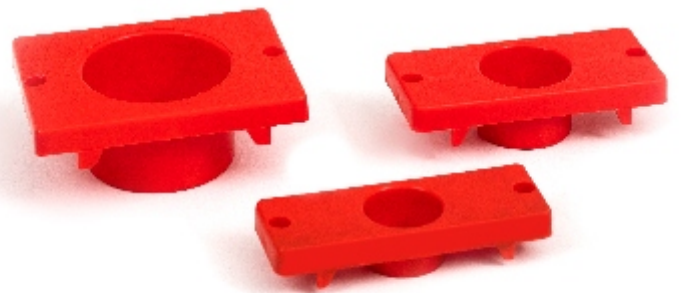

Plastic Tool Pockets

www.kppl.co.in

Best way to store, carry & protect



BT 30, 40 & 50

HSK A-50, A-63 & A-100

Overall size in mm

TYPE		L	B	H	Clamping size
BT - 30	HSK A - 50	140	51	50	125
BT - 40	HSK A - 63	140	65	65	125
BT - 50	HSK A - 100	140	104	90	125

Systematic & Vertical Storage of Tools

Protection from scratches, dents etc., to tool holder due to unique design & high quality Engineering Plastic Material

Instant identification of tools

Easy to mount with the help of Allen Bolts

Cost effective solution

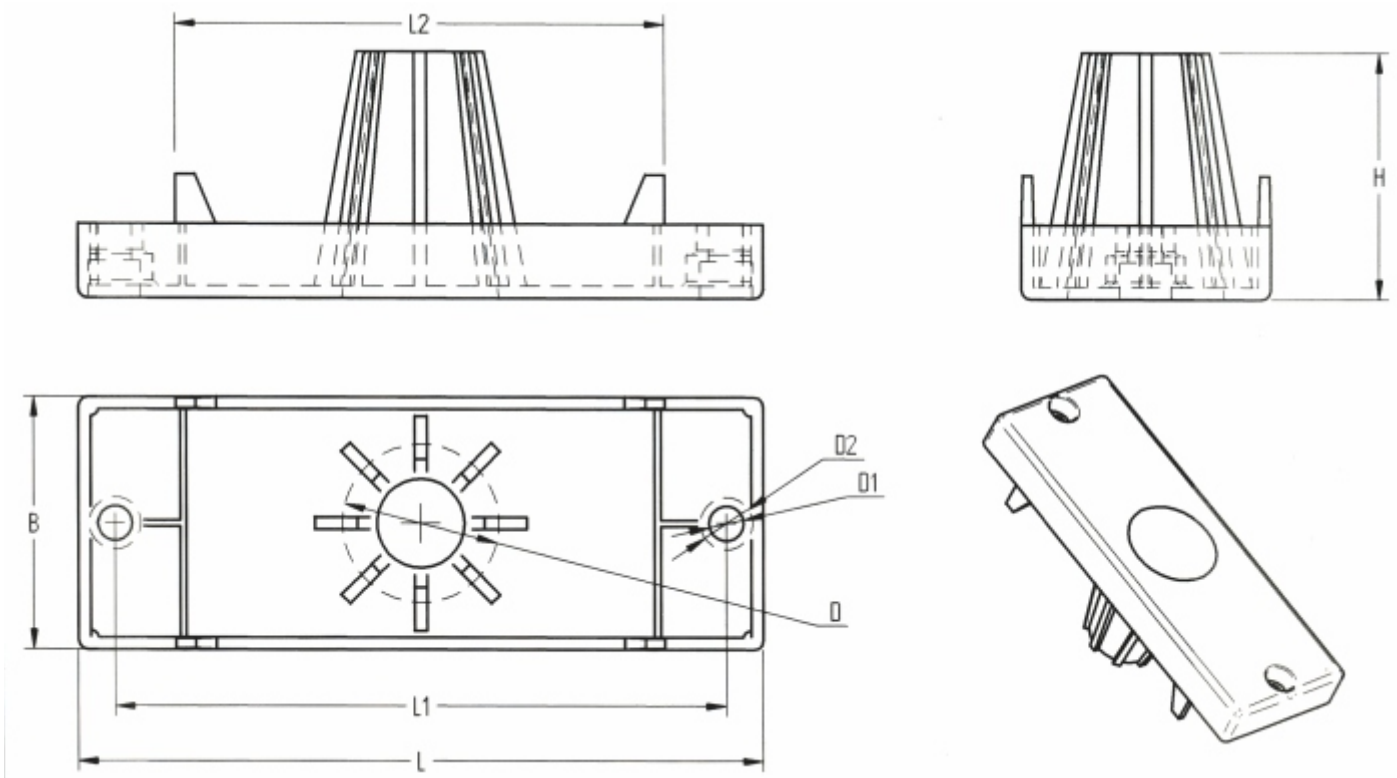

BT 30, 40 & 50

HSK A-50, A-63 & A-100

TYPE	D	D1	D2	L	B	H	L1	L2
BT - 30	32	7	10.5	140	51	50	124.5	99
BT - 40	45	7	10.5	140	65	65	124.5	99
BT - 50	70	7	10.5	140	104	90	124.5	99
HSK A - 50	38.3	7	10.5	140	51	27	124.5	99
HSK A - 63	48.4	7	10.5	140	65	35	124.5	99
HSK A - 100	75.7	7	10.5	140	104	49	124.5	99

Consider tolerance of +0.5 & -0.5mm due to Plastic Moulding Shrinkage

Dimensions are subject to Change without prior Notice due to on-going R&D

Best way to store, carry & protect



Round - BT 30, 40, 50

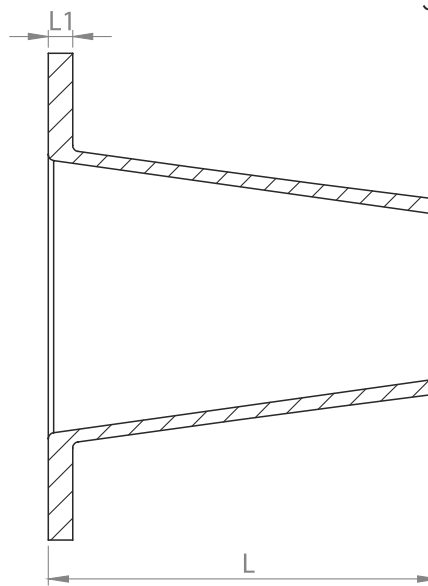
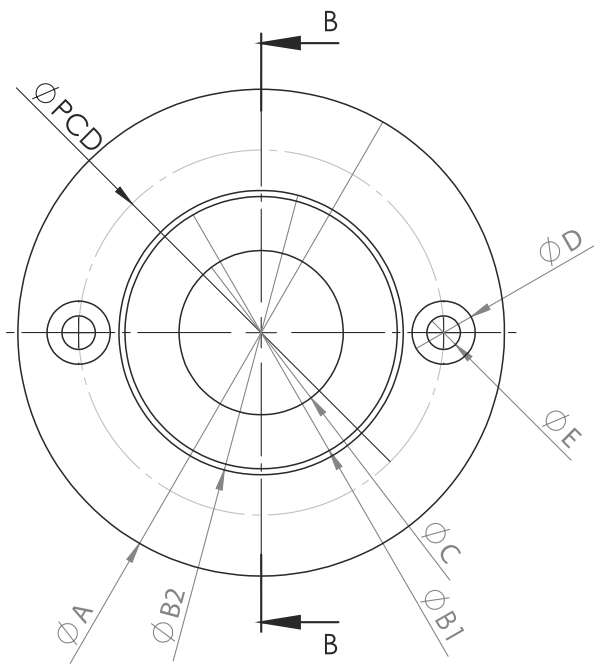

MODEL	A	B1	B2 Plate hole	C	D	E	PCD Mounting hole	L	L1
RD-BT-30	64	31.5	36.5	26.5	9	4.5	49	50	4
RD-BT-40	80	44.5	50	31.5	10.5	5.5	58.5	64	4
RD-BT-50	110	69	75.5	57.5	10.5	5.5	88	64	4.5

Consider tolerance of +0.5 & -0.5mm due to Plastic Moulding Shrinkage

Dimensions are subject to Change without prior Notice due to on-going R&D

Application of Tool Pockets

