

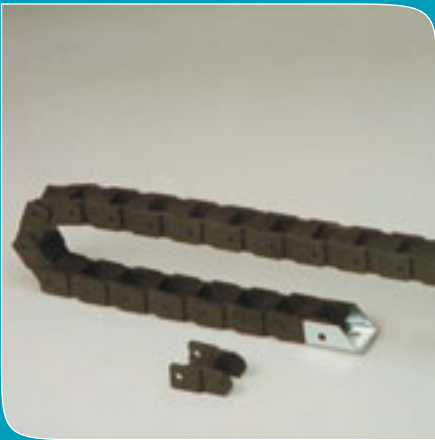

Kumbhojkar's CABLE DRAG CHAIN

DC - 0



DC - 1



DC - 2



DC - 3

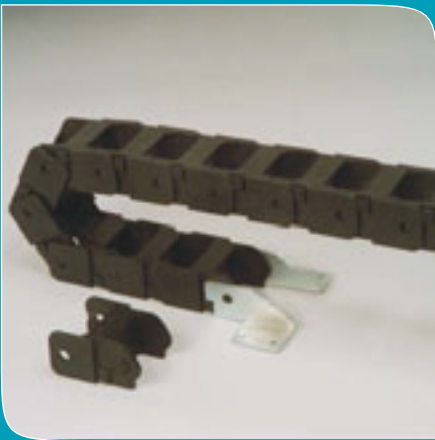

DC - 4



DC - 5



DC - 6

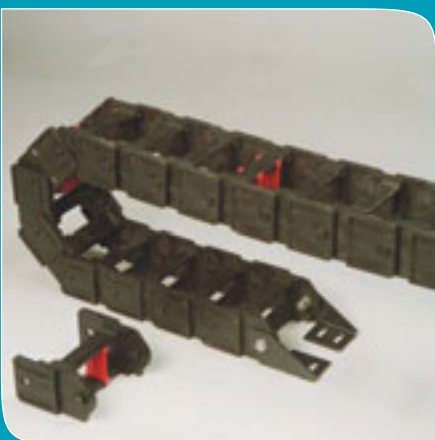

DC - 7

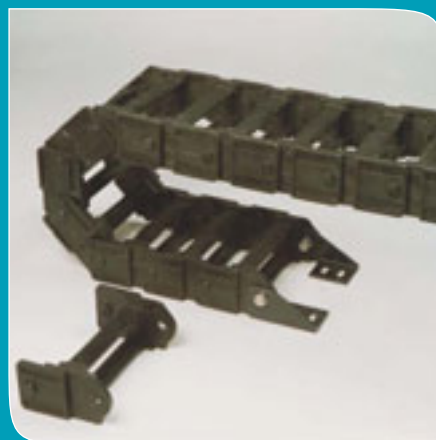

DC - 8



Metal End Clamps for DC - 6,7,8

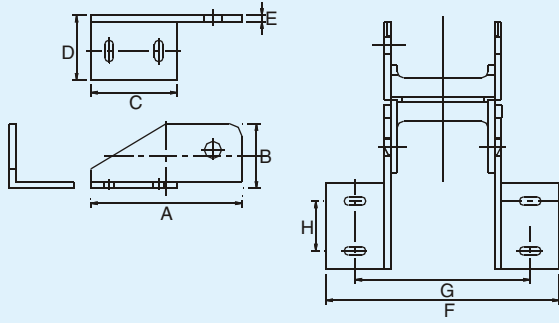

Fixed End Side Metal Clamps

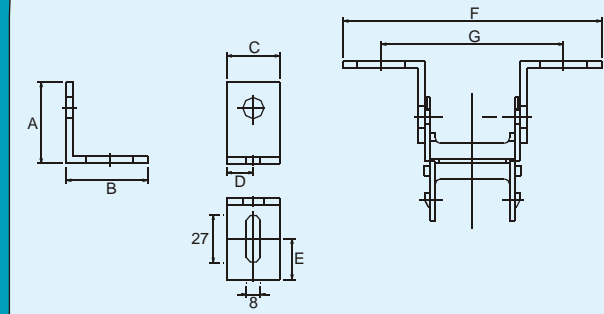

Moving End Side Metal Clamps

Clamps for	Sr. No.	A	B	C	D	E	F	G	H
DC 6	FC-6	90	45	55	50	4	213	163	23
DC 7	FC-7	90	45	55	50	4	262	212	23
DC 8	FC-8	90	45	55	50	4	313	263	23

Clamps for	Sr. No.	A	B	C	D	E	F	G
DC 6	MC-6	46	46	30	15	15	218	172
DC 7	MC-7	46	46	30	15	15	268	222
DC 8	MC-8	46	46	30	15	15	322	276

Guidelines for Installation of Cable Drag Chain

Classification :

- TL** Total length of Travel
- UL** Unsupported Length
- BR** Bending Radius
- MH** Height of Moving End

- DL** Length of Drag Chain
- BL** Length of Drag Chain in Bend
- P** Pitch
- F** External height of Drag Chain

1. The fixed end of the cable carrier should be in the centre of the total travel length (TL). This arrangement results in minimum length of Drag Chain.

2. Unsupported Length (UL)
$$UL = \frac{TL}{2}$$

3. Length Of Drag Chain (DL)
In long travel the upper links may glide on the lower links without hampering the motion. The portion glides easily on top of one another as all is made in plastic. However to avoid this we suggest you to use supports/guide channels below the sagging parts.

$$DL = \frac{TL}{2} + BL$$

4. Length of Drag Chain in Bend (BL)

$$BL = BR \times \left[\pi + 2P \right]$$

5. Height of Moving End (MH)

$$MH = 2BR + F$$

6. The movement of Drag Chain should be on smooth surface otherwise we suggest use of

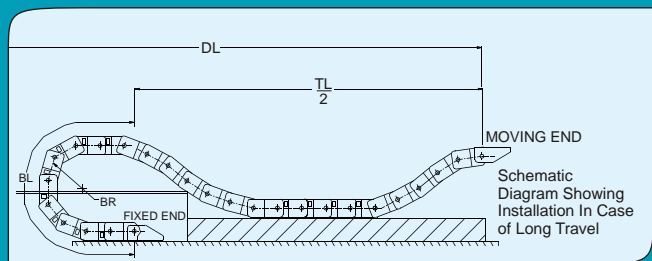
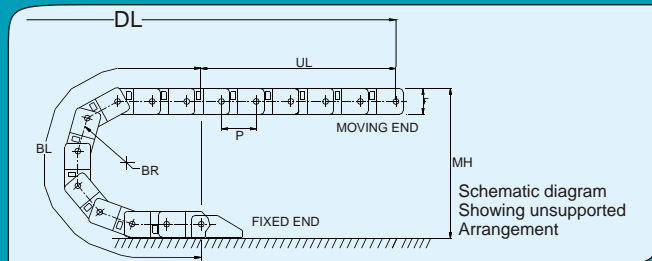

guide channels. These channels fitted on the side of Drag Chain facilitate movement during return stroke of chain when it comes to its original position and does not deviate side ways from the fixed points thus avoiding tension & breakage.

Ps. : Kindly note above mentioned are guidelines for your reference while installation of drag chain, However we recommend you to take expert opinion from your installation engineers.

Ways

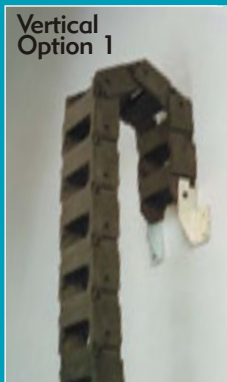
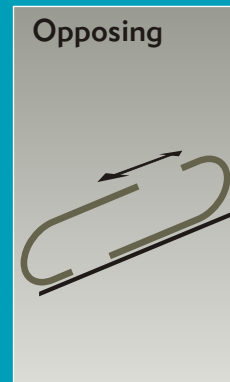
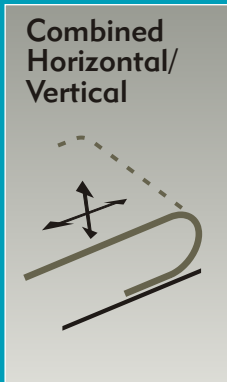

Kumbhojkar's Cable Drag Chain designed, developed & manufactured in Pune from 1986. This system is a reliable solution to carry cables & hoses in motion on almost all type of sophisticated machines like NC, CNC to rugged cranes.

Advantage - The hoses & electrical cables connected to machinery parts in motion may get damaged as direct tension is applied on them; instead the use of Drag Chain eliminates this problem as the tension is applied on Drag Chain thus keeping the Cables & hoses intact & facilitating smooth movement.

Salient features include less weight, low noise, non-conductive, easy handling, non corrosive, easy of assembly due to snap fitting, maintenance free, available in custom lengths, separators to segregate cables/hoses, can be used for

side by side in case number of cables is more, increases cable/hoses life, modular design simplifies cable/hose maintenance.

The Cable Drag Chain is **assemblies** of single units that are snap fitted to form chain to specific length.

New Introduction

Model DC-6, DC-7, DC-8

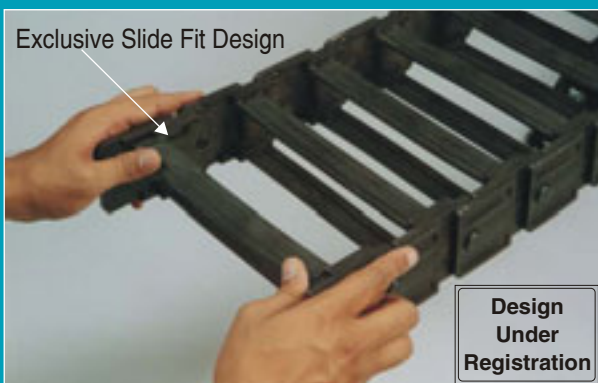

KUMBHOJKARTM PLASTIC MOULDERS

129, Narayan peth, Sitaphal Baug Colony, Near Mati Ganpati, Pune : 411 030. Tel.: 020-24450055/24450060.

Fax : 020-24480544, Website : <http://www.plamoulds.com>. Email : kpss@plamoulds.com

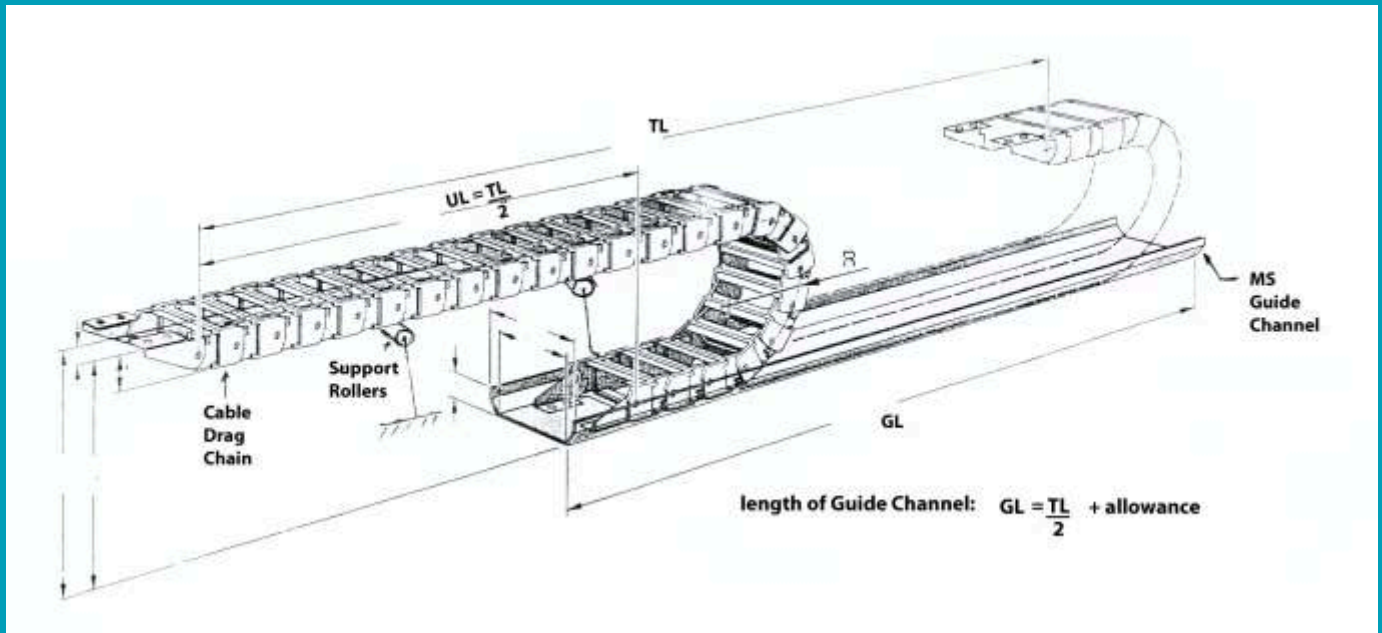

GUIDELINES FOR USE OF GUIDE CHANNEL

A Guide channel / Support Tray is always necessary for smooth functioning of the Drag Chain. Especially in case of Long Travel Guide Channels are a must.

We suggest that inner width of guide channel should be approximately 5mm more than drag chain width & 2mm on either side tapered on the outer side.

The height of guide channel must be minimum half of the total height of the drag chain link. In case of Long Travel the Guide Channel has to be fitted with Support Rollers so as to guide the drag chain and thus prevent it from falling or in case where the top portion cannot glide on the lower portion of drag chain. The Spacing & Number of such Support Rollers will vary as length increases.

The guide channels need to be fixed & aligned in a straight line with no protruding parts on the inner side like bolt heads/ nuts etc. as these may entangle with Drag Chain restricting its motion & breaking it eventually.

Ps. : Kindly note above mentioned are guidelines for your reference while installation of drag chain, However we recommend you to take expert opinion from your installation engineers.



KUMBHOJKAR PLASTIC MOULDERS

129, NARAYAN PETH, SITAPHALBAUG COLONY, NEAR MATI GANPATI, PUNE : 411 030. INDIA.
 TEL. : 020-24450055/60, FAX : 020-24480544 E-Mail : kpss@plamoulds.com WEB SITE : <http://www.plamoulds.com>



Drag Chain

Guidelines for assembly of Drag Chain models DC-6 onwards with "New Design" - Plug + Cylinder Button.

1

2

3

Drag Chain assembly in three simple steps.

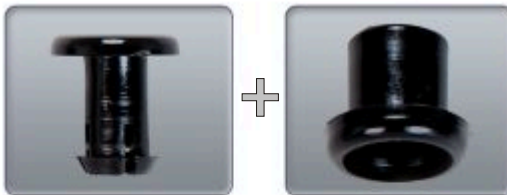

Plug

Cylinder



Assembly of Plug Cylinder Design Button

1

Arrange the drag chain and plug cylinder as displayed in the picture.



2

Place cylinder from outside and plug from inside by hand.

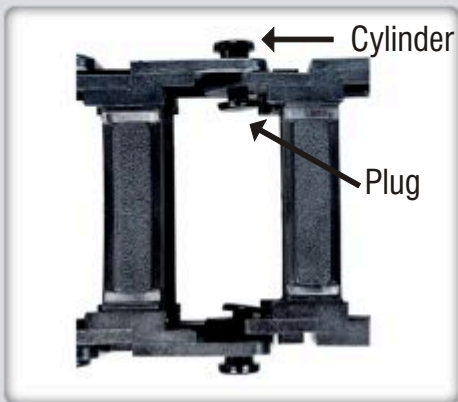

3

Press the plug cylinder with plier to complete the assembly.



NEW DEVELOPMENT

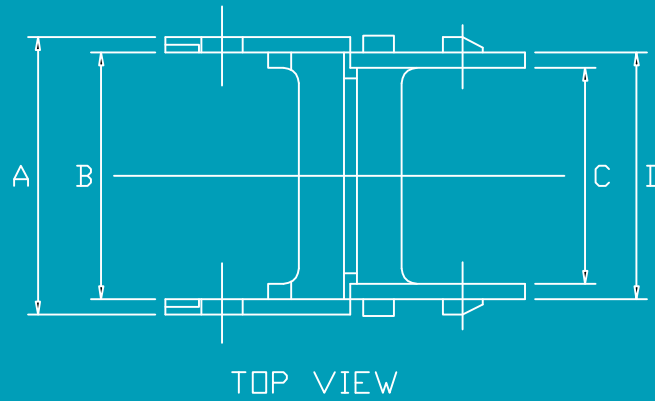
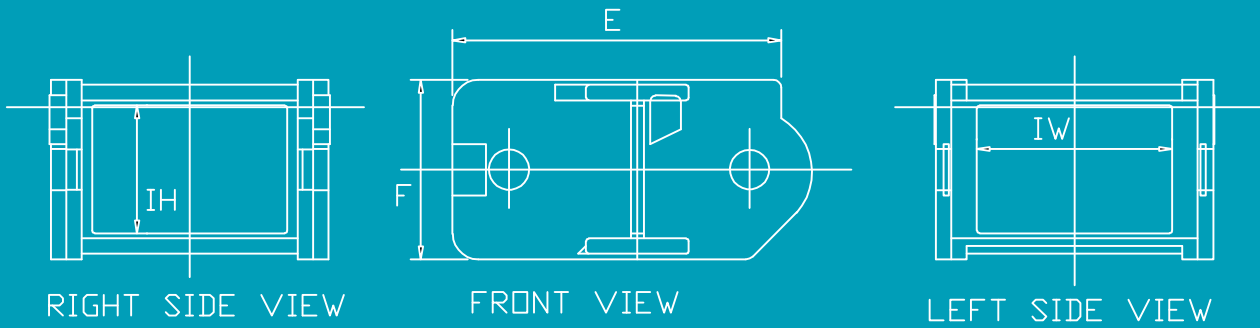

SR.NO	A	B	C	D	E	F	Width IW	Height IH	Bend.R.	LINKS/Mtr.
DC-6-A 125mm	152	140	125	140	110	63	125	40	100	13NDS.

A & F ARE THE OUTERMOST SIZES

NOTE : METALLIC END CLAMPS ARE AVAILABLE FOR ALL SIZES OF DRAG CHAIN
WE SUGGEST YOU TO USE GUIDE RAILS FOR DRAG CHAINS

ALL DIMENSIONS ARE SUBJECT TO CHANGE WITHOUT NOTICE.			
KUMBHOJKAR PLASTIC MOULDERS 129, NARAYAN PETH, PUNE-411030 Ph-020-4450055 Fax-020-4480544	DRN.:C.D.C -6 A-125mm	CHD.:	
	22-12-08	SCALE: NOT TO SCALE	
	MATL.: MODIFIED PA		
CABLE DRAG CHAIN DC-6-A-125mm x 40mm		SHT. NO.:	01